

CGME

May, 1993

MF-9058

INSTRUCTION MANUAL

Controlled Growth Mercury Electrode

Bioanalytical
Systems, Inc
2701 Kent Avenue
West Lafayette
Indiana 47906

MANUFACTURER'S NOTE

This instrument, either wholly or in part, is manufactured for research purposes only. Use for medical diagnosis is not intended, implied or recommended by the manufacturer. Use for this purpose and accountability for the same rests entirely with the user.

TABLE OF CONTENTS

Section 1. INTRODUCTION	1
SAFETY CONSIDERATIONS.....	1
FEATURES	1
SPECIFICATIONS	2
TECHNICAL CHANGES	2
DAMAGED SHIPMENTS.....	2
PRODUCT WARRANTY.....	3
WARRANTY CARD.....	3
EXTENDED WARRANTY AGREEMENT	3
SERVICE INFORMATION	4
Section 2. INSTALLATION	5
INSPECTION OF SHIPMENT	5
FRONT PANEL CONTROLS AND CONNECTIONS	6
BACK PANEL CONTROLS AND CONNECTIONS	6
LOCATION OF CGME	9
POWER REQUIREMENTS	9
Voltage Selection.....	9
Fusing Arrangement	9
Fuse Rating	10
CGME CONNECTIONS	10
Power Cord Connection	10
CGME to BAS 100 Series Electrochemical Analyzer	11
CGME to CV-50W Voltammetric Analyzer	12
CGME to CV-27 Voltammograph	12
CGME to CV-1B Voltammograph.....	13
CGME to Non-BAS Instruments.....	13
Gas Inlet Connection	13
Cell Placement	14
Electrode Leads	14
Purging/Blanketing Lines	14
Section 3. OPERATION	15
MECHANICAL PRINCIPLES OF CGME	15
STARTUP	16
Capillary Installation.....	16
Drop Knocker Strength Adjust	17
DROP MODES	17
DROP SIZE	18
REMOTE CONTROL.....	19
GAS PURGE	20
STIR	20
FARADAY CAGE	20
USE OF SOLID WORKING ELECTRODES.....	20
SHUTDOWN	20

Section 4. MAINTENANCE	21
GENERAL MAINTENANCE.....	21
Cleaning the Capillary	21
Silanizing the Capillary	22
Electrode Resistance.....	22
Replacment of the Valve Seal	23
TROUBLESHOOTING	23
SERVICE PROCEDURE	25

Section 1. INTRODUCTION

The patented Controlled Growth Mercury Electrode (CGME) was developed from the work of Drs. Zygmunt Kowalski (Institute of Materials Science, Krakow) and Janet Osteryoung (N.C. State University) who collaborated at SUNY Buffalo (U.S. Patent No. 4,846,955). It was specifically developed as an accessory for the BAS 100 series and CV-50W electrochemical analyzers. As such, the electrode functions, including stirring and purging can be controlled either remotely or manually. The CGME has its own power supply so it can be used with the CV-27 Voltammograph and many commercial and home built instruments as well. This easy to use electrode has the advantage of a reliable low-resistance electrical contact to the mercury filament. Its unique fast response valve permits precise incremental control of mercury to the forming drop. The design was engineered to minimize the chance of mercury spillage.

SAFETY CONSIDERATIONS

Excessive mercury exposure is a health hazard. Even though the CGME is designed to minimize the chance of accidental mercury spills, the CGME should be placed in a plastic tray to contain the mercury droplets should a spill occur. Mercury is volatile so spills should be cleaned up immediately. Mercury spill kits are available commercially. Waste mercury should be in a sealed container or covered with water if in an open container. Dispose of mercury waste according to regulations.

FEATURES

- Complete package
- Self contained power supply
- Low resistance
- Easy maintenance
- Three cell modes - DME, SMDE, CGME
- Wide range of drop sizes
- Manual or remote control of mercury dispense
- Manual or remote control of drop knocker
- "Quick-connect" input gas line connector
- Manual or remote control of gas purge-blanket
- Manual or remote on-off control of magnetic stirrer
- Manual 16-position adjustment of magnetic stirrer rate
- Small volume glass cell vials
- Mounted cell top compatible with all BAS solid working electrodes and reference electrodes
- Cell lead connects directly to all BAS electrochemical controllers (Voltammographs or Electrochemical Analyzers)
- Standard addition port

SPECIFICATIONS

Power:

110-120/220-240 VAC, 50/60 Hz, V-A 10 Watts

Main Fuse:

1.0 A Slow Blow at 110-120 VAC

0.5 A Slow Blow at 220-240 VAC

Inlet Gas Pressure:

5 psi maximum

Size:

Approximately 7.25" (18 cm) wide x 9" (23 cm) deep x 16.5" (42 cm) high

Weight:

Approximately 13.5 lbs (6 kg)

TECHNICAL CHANGES

We reserve the right to make technical changes to improve the instrument. Minor changes will be self-evident; improvements affecting use or maintenance will be described in supplementary pages to this manual.

DAMAGED SHIPMENTS

If any damage has occurred whether obvious or concealed, all claims must be made to the carrier usually within 15 days of your receiving the shipment; otherwise the carrier may not honor the claim. Once the item has been assigned to a carrier for shipment, the carrier is responsible for its safe delivery. The following are some guidelines to follow when damage is discovered. You should contact the carrier directly for specific claim procedures.

United Parcel Service (UPS), Parcel Post, Air Parcel Post.

1. Retain container, packing material, and broken item for inspection by the carrier.
2. Write or phone BAS with our order number, the date received and a description of the damage. BAS will do everything possible to expedite repair or replacement of the items damaged.

Air Freight, Express or Truck

1. Contact the local agent of the transportation company immediately and request an inspection.
2. Retain the container, packing material, and damaged goods until the examining agent has made an inspection report.

In all of the above cases, do not return damaged goods to Bioanalytical Systems without first contacting our customer service personnel for a Return Authorization Number (RA#). When a defective part is returned to BAS, the RA number immediately identifies you as the sender and describes the item being returned. To avoid confusion, BAS refuses all unauthorized return shipments.

PRODUCT WARRANTY

Bioanalytical Systems Inc. (BAS) warrants equipment manufactured by the company to be free from defects in material and workmanship for a period of 1 year from the date of shipment, except as provided hereinafter. This assumes normal usage under commonly accepted operating parameters. BAS agrees to either repair or replace, at its sole option and free of part charges to the buyer, any parts of such instrumentation which, under proper and normal conditions of use, prove to be defective within 90 days from date of shipment. Electrochemical cells and working electrodes are warranted for 60 days. This warranty and remedy are given expressly and in lieu of all other warranties, expressed or implied, of merchantability or fitness for particular purpose and constitutes the only warranty made by BAS.

BAS neither assumes nor authorizes any person to assume for it any other liability in connection with the sale, installation, service, or use of its instrumentation. BAS shall have no liability whatsoever for special, consequential, or punitive damages of any kind from any cause arising out of the sale, installation, service, or use of its instrumentation.

All products manufactured by BAS are tested and inspected prior to shipment. Upon prompt notification by the Buyer, BAS will correct any defects in warranted equipment of its manufacture either (by our option) by return of the item to our factory, or shipment of a repaired or replacement part. BAS will not be obliged, however, to replace or repair any piece of equipment which has been abused, improperly installed, altered, damaged or repaired by others. Defects in equipment do not include decomposition, wear, or damage by chemical action or corrosion.

Limited obligations covered by this warranty include:

- a. In the case of instruments not of BAS manufacture, the original manufacturer's warranty applies.
- b. Shipping charges under warranty are covered only in one direction. The Buyer is responsible for shipping charges to the factory, if return of the part is required.
- c. Expendable items including carbon paste, reference electrodes, source lights, panel lights, and fuses are excluded from warranty.

WARRANTY CARD

Each BAS CGME is shipped with a warranty card which should be completed and returned by the end user. This card will enable us to identify and contact the individual responsible for operation of the instrument. Please return the card as soon as possible so that we may inform you of product updates and other pertinent technical information.

EXTENDED WARRANTY AGREEMENT

BAS offers an extended warranty "Full Protection Maintenance Service Agreement" to customers purchasing this system. Please contact your Sales Representative or the Service Department at BAS for further details.

SERVICE INFORMATION

Bioanalytical Systems provides a skilled service staff available to solve your technical and equipment-oriented problems. For service, call (317) 463-4527 ext. 207 during normal working hours (Eastern Standard Time the year around) and ask for Customer Service. Following discussion of your specific difficulties, an appropriate course of action will be described and the problem resolved accordingly.

Do not return any products for service until a Return Authorization Number (RA#) has been obtained. The RA# identifies you as the sender and describes the problem you are having in full detail. Estimated service turn around time can be quoted when RA# is issued, although the actual time cannot be determined until the equipment is received and the problem verified. All correspondence and shipments should be sent to:

Service Department
Bioanalytical Systems, Inc.
2701 Kent Avenue
West Lafayette, Indiana 47906
RA# _____

Section 2. INSTALLATION

INSPECTION OF SHIPMENT

After carefully unpacking the instrument, check the contents of the packages and inspect for breakage. Table 1 lists the parts of the CGME. This list is subject to change. Please refer to the packing slip with your instrument to verify the parts. Assembly of these various parts will be outlined in the following chapters.

Please retain the shipping box and packing material until you have fully tested the unit to be certain that no damage was incurred during shipping.

If a shortage exists, call BAS Customer Service and describe the shortage. A replacement part will be sent immediately subject to stock availability.

Table 1 Parts List of CGME Package

Capillary
Stir Bar
Voltammetry Cells
Ag/AgCl Reference Electrode (3)
Platinum Wire Auxiliary Electrode
Gas Connection Tubing
Cables
Hand Vacuum Pump with Mercury Trap
Instruction Manual

**FRONT PANEL CONTROLS
AND CONNECTIONS**

1. Power LED, LED is lit when CGME is powered (on/off switch located on back panel)
2. Dispense Push Button. Mercury will be dispensed each time the button is pressed. The amount of mercury is determined by size switch (#5).
3. Knock Push Button. The drop knocker will engage each time the button is pressed. The strength of the knock is determined by the adjustment on the back panel.
4. Dispense LED. The LED is lit when power is supplied to the solenoid which opens the valve for dispensing mercury.
5. Drop Size Switch. Switch for selection of one of 16 available drop sizes.
6. Stir LED. LED is lit when stir is turned on, either manually or remotely.
7. Stir Rate Switch. Switch for selection of one of 16 available stir rates.
8. Stir Control. Switch to manually control stirrer or to select for remote control.
9. Gas Purge LED. Led is lit when gas purge is turned on for sample vial, either manually or remotely. When LED is off, the gas flows through blanket line.
10. Gas Purge Flow Control. Needle valve control of gas flow to purge and blanket lines.
11. Gas Purge Control. Switch to manually control gas flow to purge or blanket lines or to select for remote control.
12. Working Electrode Lead. Black lead connected to contact of mercury reservoir.
13. Auxiliary Electrode Lead. Red lead connected to platinum wire auxiliary electrode.
14. Standard Addition Port.
15. Reference Electrode Lead. White lead connected to reference electrode.
16. Height adjustment knob for cell top.
17. Stir Motor.
18. Ground socket for Faraday Cage
19. Mode Switch. Switch for selection of one of the three available modes: CGME (Controlled Growth Mercury Electrode), DME (Dropping Mercury Electrode), or SMDE (Static Mercury Drop Electrode).
20. Valve gap adjustment knob.
21. Valve seal adjustment knob.
22. Electrode height adjustment knob.
23. Reservoir fill/drain port.
24. Capillary.
25. Gas purge and blanket lines.
26. Drop knocker.

**BACK PANEL CONTROLS
AND CONNECTIONS**

27. Remote connector. 25 pin D connector for remote control of CGME.
28. Cell Lead Connector.
29. Drop Knocker strength adjustment.
30. Gas inlet connector for cell purging. Bulkhead fitting providing connection to external gas source. NOTE: 5 psi maximum.
31. Power on/off switch.
32. Power cord. Be sure that the 3-prong power cord is connected to a grounded outlet.
33. Fuse holder/voltage selection. Shows the selected line voltage.

Figure 1 Front Panel

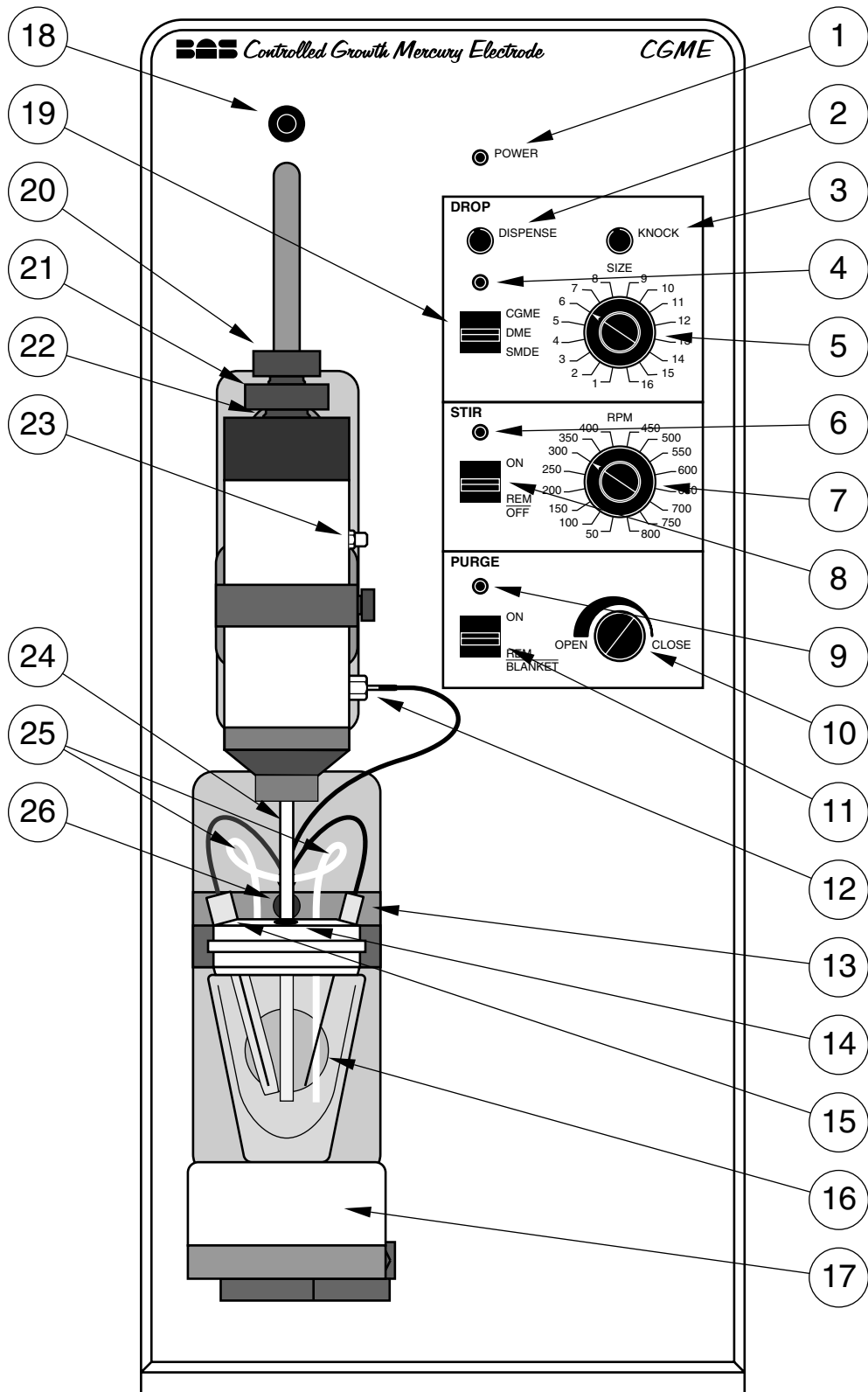
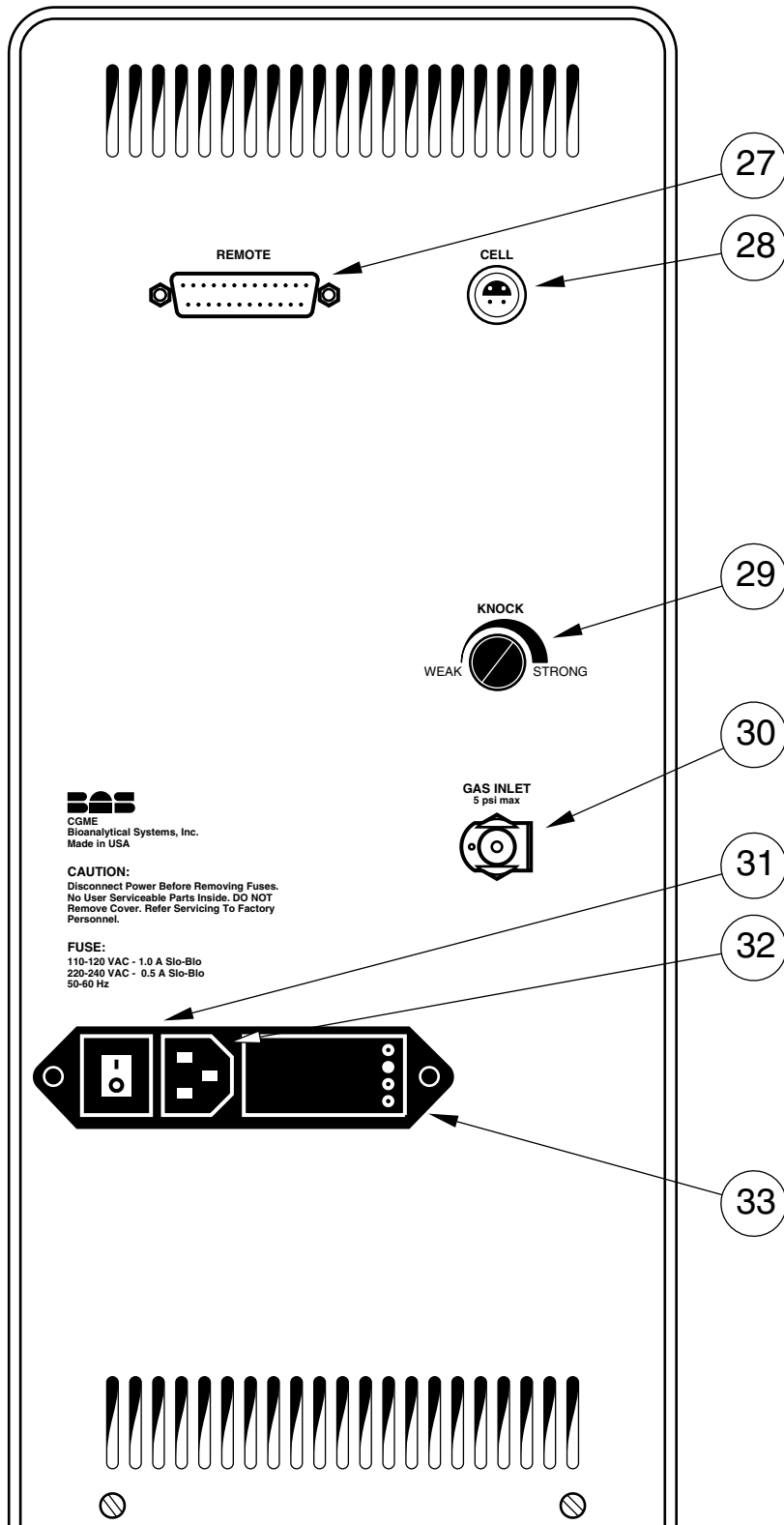

Figure 2 Back Panel



LOCATION OF CGME

1. Provide a surge-free power source. Other laboratory instruments such as ovens, vortex mixers, centrifuges, and large motors may cause spikes in the power supply.
2. Ensure that all components of the system share the same ground circuit. This can best be accomplished by plugging all components into a multi-outlet power strip. Plugging the components into independent outlets can produce ground loops (current that flows between ground circuits at slightly different potentials) which can produce baseline noise.
3. Locate the CGME on a stable bench. Vibrations can cause noise or dislodge drop.
4. Select a room where temperature remains stable throughout the day. Avoid installing the CGME near windows, air ducts, ovens, or refrigerators. Diffusion coefficients can change by 3%/°C. A water jacketed cell may be required for very precise work.
5. Place the CGME away from busy, congested areas. Remote, isolated areas are best for high-sensitivity work.
6. Avoid very dry areas and areas that are carpeted. Static electricity can affect instrument performance. Anti-static floor mats and bench mats are useful if spiking caused by static charge is a problem.
7. Avoid areas where radio-frequency interference is likely. Beeper-type paging devices can be a problem in some installations.

POWER REQUIREMENTS

The CGME can be used with either 110V or 220V (50-60 Hz) power supply. Make sure that the position of the voltage select card corresponds to the local power supply.

Voltage Selection

Should the power option need to be changed, unplug the line cord and open the cover using a small screwdriver or similar tool. Set aside the cover/fuse block assembly and pull the voltage select card straight out of the housing, using the white plastic indicator pin. Orient the selector card so that the desired voltage is readable at bottom of card. Orient indicator pin to point straight up when desired voltage is readable at bottom. Insert the voltage selector card back into the housing, printed side of card facing the On/Off switch. The edge of the card containing the desired voltage should be inserted first. Replace cover and verify that the indicator pin shows the desired voltage.

Fusing Arrangement

To change from North American to European fusing arrangement: open cover, using a small screwdriver or similar tool. Loosen Phillips screw 2 turns, then remove fuse block from cover by lifting up and away from Phillips screw. Change fuses (note that 2 European fuses are required), invert fuse block and slide back onto Phillips screw and cover so that the 2 European fuses are up. Tighten Phillips screw and replace cover. Note that fuse(s) that go into the housing first are the active set.

Figure 3 Removal of Voltage Selector Card

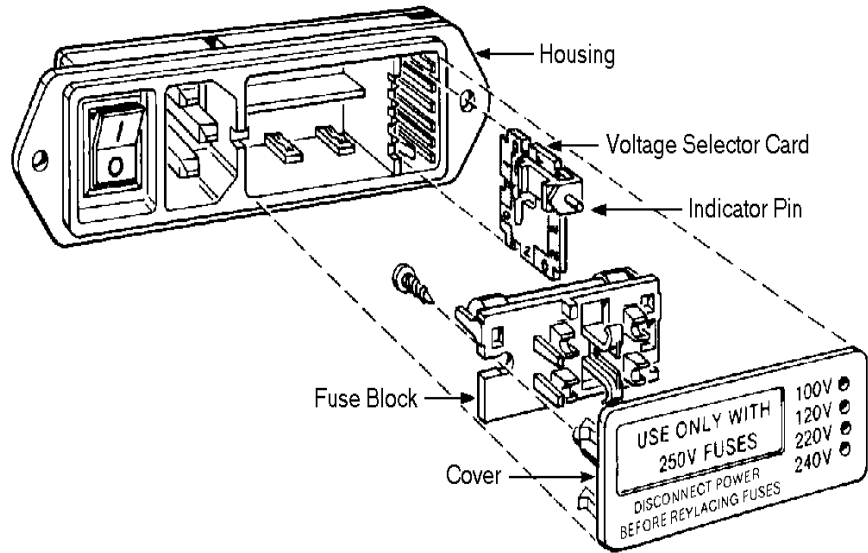
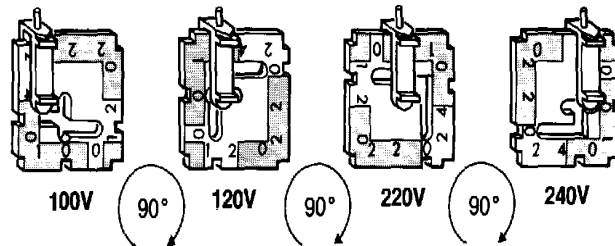

Figure 4 Voltage Selector Card Orientation



Fuse Rating

Be sure that correctly-rated fuse(s) are used:

100-120 V	1.0 Amp
220-240 V	0.5 Amp

Use of repaired fuses or short-circuiting of the fuse holder is prohibited. Connect the instrument only to sockets with a ground contact by using the three-pronged power cord included with delivery. For problem-free operation and for safety considerations, be sure that the instrument is firmly connected to a positive ground via the power cord.

CGME CONNECTIONS

This section will show the connection of the CGME to the cell and CGME controllers.

Power Cord Connection

Push the socketed (female) end of the power cord into the port on the Voltage Selector Card located in the lower center of the back-panel (See Figure 3.3). Before making this connection, make certain the power on/off switch is in the off position. This switch is labelled with a 0 and 1. When 0 is pushed, the power is off and when 1 is pushed, the power is on.

Figure 5 Power Cord Connection

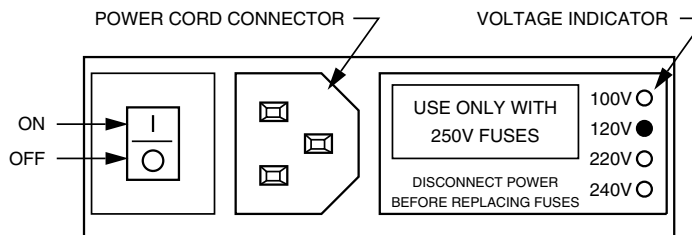

CGME to BAS 100 Series Electrochemical Analyzer

Two cables are required for connection of the CGME to the BAS 100/A/B. The drop functions, stirring, and purging can be automatically controlled by the 100/A/B. The control cable is a 25 line ribbon cable (P/N ER-9517) between the REMOTE connector (25 pin D, male) on the back of the CGME and the CELL STAND connector (25 pin D, female) on the back of the BAS 100/A/B. See Figure 6.

The connection of the cell lead cable is also shown in Figure 6. The cell lead cable has a stainless steel LEMO connector on each end. One end is inserted into the CELL socket on the back of the CGME. The other end is inserted into the CELL socket on the back of the BAS 100/A/B. Both ends are identical, therefore it does not matter which end is connected to the BAS 100/A/B and which end is connected to the CGME.

Figure 6 Connection of CGME to BAS 100B/W Electrochemical Workstation

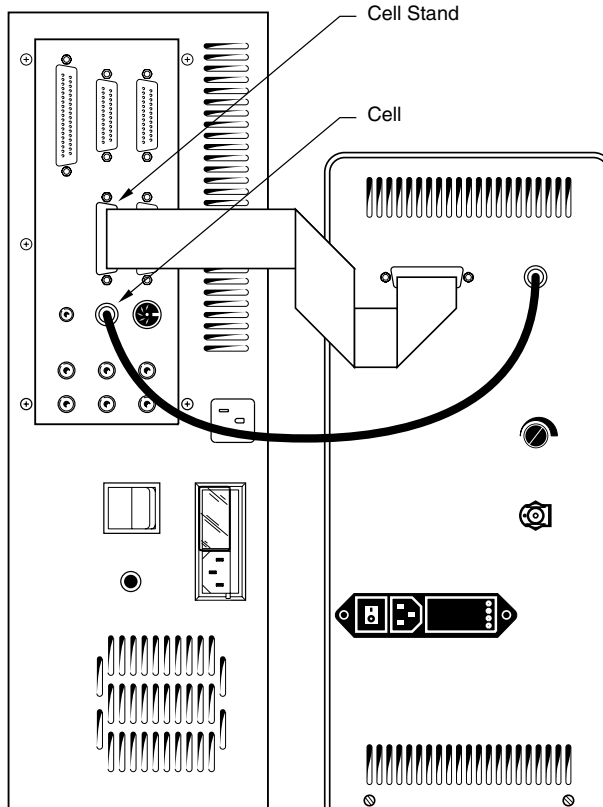

CGME to CV-50W Voltammetric Analyzer

Two cables are required for connection of the CGME to the CV-50W. The drop functions, stirring, and purging can be automatically controlled by the CV-50W. The control cable is a 25 line ribbon cable (P/N ER-9517) between the REMOTE connector (25 pin D, male) on the back of the CGME and the CELL STAND connector (25 pin D, female) on the back of the CV-50W. See Figure 7.

The connection of the cell lead cable is also shown in Figure 7. The cell lead cable has a stainless steel LEMO connector on each end. One end is inserted into the CELL socket on the back of the CGME. The other end is inserted into the CELL socket on the back of the CV-50W. Both ends are identical, therefore it does not matter which end is connected to the CV-50W and which end is connected to the CGME.

Figure 7 Connection of CGME to CV-50W Voltammetric Analyzer

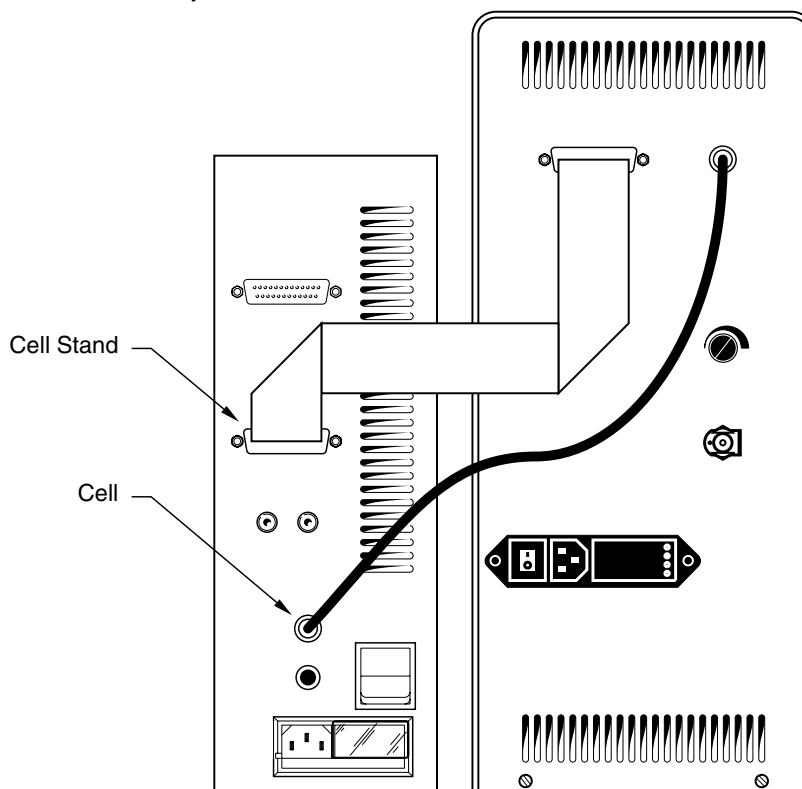

CGME to CV-27 Voltammograph

A single cable connects the CGME to the CV-27. The drop functions, stirring, and purging are manually controlled. The connection of the cell lead cable is shown in Figure 8. The cell lead cable has a stainless steel LEMO connector on each end. One end is inserted into the CELL socket on the back of the CGME. The other end is inserted into the CELL socket on the back of the CV-27. Both ends are identical, therefore it does not matter which end is connected to the CV-27 and which end is connected to the CGME.

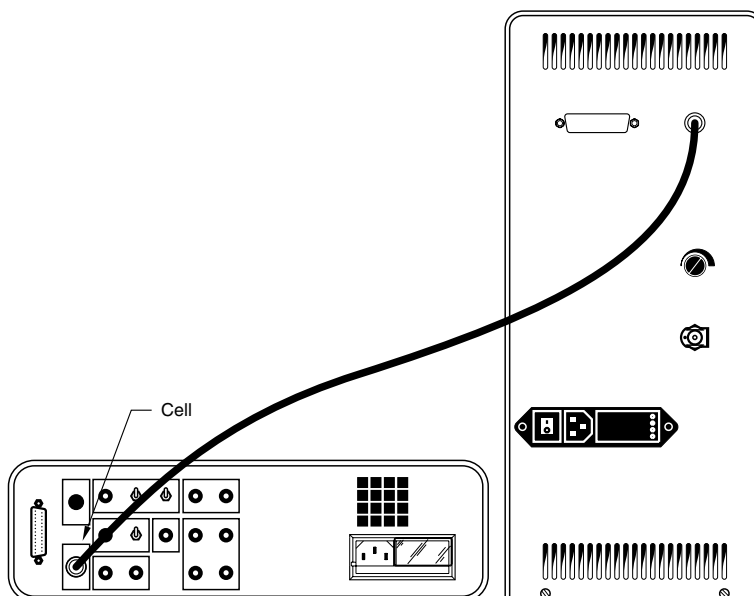
Figure 8 Connection of CGME to CV-27 Voltammograph**CGME to CV-1B Voltammograph**

A single cable connects the CGME to the CV-1B. The drop functions, stirring, and purging are manually controlled. The cell lead cable has a stainless steel LEMO connector on each end. One end is inserted into the CELL socket on the back of the CGME. The other end is inserted into the CELL socket on the back of the CV-1B. Both ends are identical, therefore it does not matter which end is connected to the CV-1B and which end is connected to the CGME.

CGME to Non-BAS Instruments

The CGME should work, at least in the manual mode, with virtually any instrument. Cables will have to be custom made by the user. The CELL cable is modified by cutting off one of the LEMO connectors and connecting the appropriate connector for the particular instrument. Alternatively, if the instrument has a cell lead with alligator clips, then disconnect the cell leads that are on the front panel of the CGME and connect the alligator clips directly to the electrodes. If automatic control is desired, then see Section 3 for information on the pin outs of the REMOTE connector for construction of the proper cable.

Gas Inlet Connection

The CGME package contains 0.25" O.D. tygon tubing and a gas line fitting. One end of the gas line fitting is barbed to fit inside the tygon tubing. Push the barbed end into the tubing. The other end of the fitting connects to the "GAS INLET" port on the rear panel of the CGME. To attach the line, simply push the connector into the port. A retaining clip will snap into place (See Figure 9). The open end of the tygon tube is connected to a regulated gas supply. The inlet gas pressure must not exceed 5 psi. To remove the tube from the CGME, squeeze the retaining ring tab against the connector and then pull the tube and connector away from the CGME.

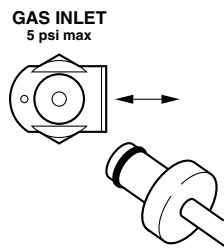
Figure 9 Gas Line Connection to CGME

Cell Placement

The CGME is designed for easy cell replacement and to accommodate both regular cells and water-jacketed cells. The cell is held in place by the stir motor. Follow these instructions for initial cell placement.

1. Pivot the stir motor to the right.
2. Bring the cell up from underneath, around the electrodes, and seat on the cell top.
3. Pivot the stir motor back under the cell.
4. If required, the cell top height can be adjusted by loosening the cell height adjustment knob, sliding the cell top assembly to the desired position, and tightening the knob.
5. The height of the capillary tip can be adjusted by loosening the electrode height adjustment knob, sliding the electrode assembly to the desired position, and tightening the knob.
6. Three 0.25" holes are in the cell top. These holes are for the auxiliary electrode, reference electrode, and standard addition port. Place the electrodes and port plug in the holes which are the most convenient.

Electrode Leads

The wires coming through the front panel are the electrode lead wires. The connectors are the spring-loaded press-on type. Simply push the connector over the corresponding pin on the electrode to make the connection. The wires are color coded to the electrode it attaches. The code is:

Black	Working
White	Reference
Red	Auxiliary

Purging/Blanketing Lines

The cell stands have the ability to purge or blanket the sample solution with an inert gas. The purge removes oxygen by bubbling an inert gas, typically nitrogen, helium or argon, through the solution. The blanketing function is to maintain an inert atmosphere above the sample to keep the oxygen or air components from re-entering the sample solution.

The purge/blanket lines are the two plastic tubes coming out of the cell top support block. These two lines should be pressed into the teflon cell top. The blanket line should extend to just beyond the bottom of the cell top. The depth of the purge tube should be near the bottom of the cell vial.

Section 3. OPERATION

MECHANICAL PRINCIPLES OF CGME

The mechanism of the CGME is protected under U.S. Patent No. 4,846,955. A basic knowledge of the electrode principles will help in understanding the reasons for the specific instructions when setting up and adjusting the CGME. A cross sectional view of the electrode is shown in Figure 10. The capillary has a stainless steel tube embedded in the top end of the capillary. Mercury flow through the capillary is controlled by a fast response valve. The valve is a rubber plug at the end of a shaft which when displaced slightly up will allow mercury to flow. Since the contact between the filament of mercury in the capillary and the reservoir is a stainless steel tube, the electrode has low resistance. The total resistance from the contact point to the mercury drop is about 7 ohm. Less than 0.2 ohm is due to the stainless steel contacts, the vast majority of the resistance is due to the small column of mercury in the capillary. The valve seal is controlled by the valve seal adjustment knob. The top of the shaft and the bottom of the valve gap adjustment knob assembly are made from ferromagnetic material. This area is surrounded by a coil of wire to form a solenoid. When the coil is energized, the shaft moves up. The click sound results from the two metal pieces hitting together. The amount that the valve is allowed to open is controlled by the valve gap adjustment knob. The proper distance should be 0.3 - 0.4 mm. After a little use, the clicking sound can be used as rough measure whether the valve opening is correct. A spring is used to close the valve when the power is removed from the solenoid.

Figure 10 Section View of Electrode

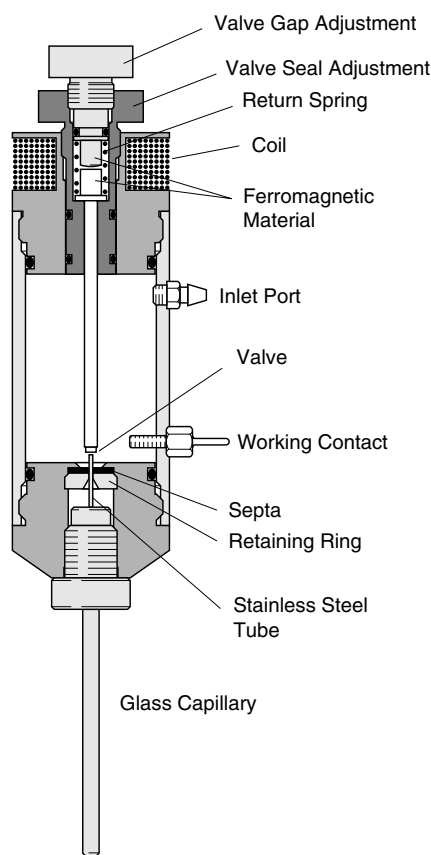

It is imperative that trapped air bubbles be removed from the reservoir for proper operation of the CGME. O-rings between all the parts of the electrode body permit an air tight seal. A vacuum can be applied to the inlet port to remove air bubbles. The septa which the steel capillary tube passes through gives an air tight seal when in use and prevents mercury from leaking from the reservoir when the capillary is removed. Rotating the electrode 90°, and then slowly returning to the vertical position with slight agitation should remove trapped air. The electrode should be rotated 90° when first filling the reservoir and the mercury level should not be above the side of the shaft. Over filling may cause mercury to get into the solenoid chamber during vacuum degassing.

STARTUP

The electrode should be placed on a plastic tray to catch any mercury droplets which may escape when setting up the instrument.

Capillary Installation

1. Raise electrode to top of stand.
2. Rotate electrode 90°, so that the mercury fill port is pointing up.
3. Insert capillary into the threaded hole, be sure steel tube on top of capillary goes through hole in center of septa in the hole.
4. Tighten capillary. Watch end of steel tube while tightening. Do not let steel tube touch the rubber valve seal. It may be necessary to turn valve seal adjustment knob counter clockwise to leave a gap between the rubber seal and steel tube.
5. High purity triple distilled mercury is required for proper operation of the instrument. Insert syringe needle in middle of mercury container. Pull back on syringe plunger to draw mercury into syringe, leaving all the oxidized layer in container.
6. Insert the syringe needle into the mercury fill port. Add mercury to the reservoir until the mercury touches bottom of the shaft. DO NOT OVERFILL.
7. Rotate electrode 90° so capillary is pointing down.
8. If mercury flow has not started, then use a pipet bulb to pressurize reservoir to initiate flow of mercury through capillary. Note mercury should now be freely flowing down capillary and drops should be forming (and dropping off) at the orifice. Slowly tighten valve seal adjustment knob until mercury flow stops. Turn knob an additional 1/16 turn clockwise. Do not over tighten or the steel tube may puncture the rubber valve seal.
9. Tighten gap adjust knob, then turn knob 1/3 turn counter clockwise.
10. Turn drop size knob to 12. Push dispense button and watch drop to insure that mercury flows when the valve is open and stops when the valve should be closed.
11. Removal of trapped air from reservoir is required for proper operation of the CGME. Connect the mercury trap to the CGME as shown in Figure 11. The clamps on the tubing should be open. Connect the mercury trap to hand vacuum pump supplied (water aspirator would work also). The gauge should read approximately 25". Turn mercury electrode 90°, with inlet port pointing up. Slowly turn electrode back to vertical position with the capillary pointing down.

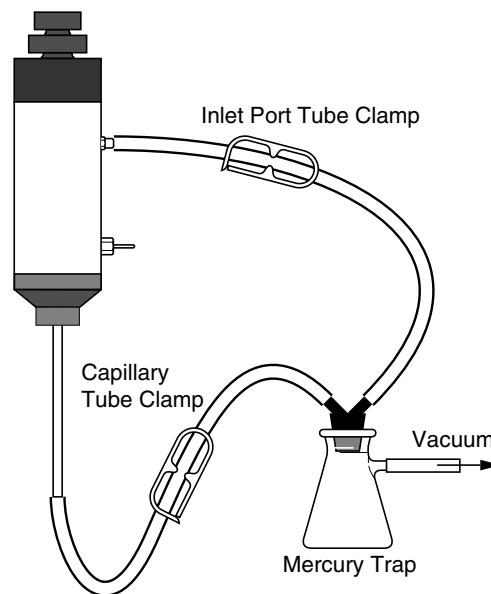
Figure 11 Mercury Trap

12. Close tube clamp to the inlet port.
13. Slowly remove tubing from the inlet port.
14. Press dispense button several times until no air bubbles are seen to move down the capillary.
15. Slowly remove tubing from end of capillary. Be careful not to spill mercury that is in the tubing.

Drop Knocker Strength Adjust

1. Set drop mode switch to SMDE.
2. Fill cell with solution that is to be analyzed. NOTE: The drop knocker strength must be adjusted with the capillary tip in solution, NOT in air.
3. Turn adjust knob on back panel fully counter clockwise to weak strength position.
4. Dispense a drop of mercury.
5. Press knock button. If drop is not dislodged, then turn adjust knob slightly clockwise and press knock button again. Keep repeating until drop is consistently dislodged. Do not use a stronger knock force than is required or damage to the capillary may occur.

DROP MODES

1. DME (Dropping Mercury Electrode). The solenoid is always energized, thus mercury continuously flows through the capillary. The drop size is determined by the natural drop time, i.e., it will be affected by such things as applied potential, solution, cleanliness of mercury, cleanliness of capillary, vibrations, etc. When in the DME mode, the drop knocker can be activated either manually by the front panel knock button or remotely via the rear panel remote connector. The front panel dispense button and the remote dispense line are disabled.

2. SMDE (Static Mercury Drop Electrode). The drop size is determined by the size switch on the front panel. The time the solenoid is energized (valve open) for the different settings is given in Table 2. Both dispense and knock can be activated individually by the front panel push buttons. A signal on either the knock or dispense remote lines will initiate a knock and dispense sequence. The dispense time is determined by the front panel switch.

3. CGME (Controlled Growth Mercury Electrode). This mode offers the most flexibility in control. Both knock and dispense can be controlled manually by the front panel push button. When the dispense button is pushed, mercury is dispensed for the time selected by the switch. Knock and dispense are controlled separately under remote control. A signal on the knock line will activate the drop knocker. The length of time mercury is dispensed is determined by the length of the signal to the dispense line.

DROP SIZE

Table 2 Drop size

Number	Time Solenoid is Energized
1	10 ms
2	20 ms
3	30 ms
4	40 ms
5	50 ms
6	60 ms
7	80 ms
8	100 ms
9	150 ms
10	200 ms
11	250 ms
12	300 ms
13	350 ms
14	400 ms
15	450 ms
16	500 ms

REMOTE CONTROL

The CGME drop functions, stir, and purge can be controlled remotely. The pin out of the remote control connector is shown in Table 3. All lines require TTL activation. All lines are active low (negative edge triggered), except stir which is active high.

Table 3 Pin Out for CGME Remote Connector. All control lines are TTL.

CGME	“D” Connector Pin # Function
1	Working Electrode (Cut)
14	Analog Ground
2	Reference Electrode (Cut)
15	Analog Ground
3	Auxiliary Electrode (Cut)
16	Analog Ground
4	Digital Ground
17	NC
5	NC
18	-
6	NC
19	-
7	Digital Ground
20	-
8	Stir
21	<u>Purge</u>
9	<u>Knock</u>
22	<u>Dispense</u>
10	-
23	NC
11	-
24	-
12	-
25	-
13	-

NC means there is no connection internally to these pins

- means that these pins may have a function in the future. These lines should not be connected in a custom cable.

The operation of these lines is also dependent upon the setting of the mode switch on the front panel.

DME mode. The dispense line is inactive.

SMDE mode. A low pulse ($>10 \mu\text{s}$) to either Knock or Dispense line will cause the CGME to do a knock- dispense sequence. The drop size is determined by the size switch on the front panel.

CGME mode. Knock and dispense must be individually controlled. A low pulse on the knock line will activate the drop knocker. The mercury will be dispensed as long as the Dispense line is held low.

It is recommended to use the analog cell cable rather than the remote cable for connection to the electrodes. These lines are not connected in cable ER-9517.

GAS PURGE

The flow rate of the gas and whether it is directed to the purge or blanket lines is controlled by a front panel knob and switch.

When toggled to the ON position, the gas flow is directed to the purge line and cannot be changed by remote control. When switched to the REMOTE/BLANKET position, the gas is directed to the blanket line. It must be in this position to externally control PURGE via the REMOTE connector on the back panel. The gas flow rate to the purge and blanket lines is controlled by rotating the OPEN/CLOSE knob.

STIR

The CGME has a precisely controlled magnetic stirrer. The stirrer can be controlled either by the front panel switches or remotely. When the stir switch is toggled to the ON position, the stirrer is on at the rate selected by the rate switch (50-800 RPM) and cannot be remotely controlled. The REMOTE position is required for remote control of the stirrer. The LED is lit when the stir function is turned on either manually or remotely.

FARADAY CAGE

The CGME is supplied with a Faraday cage. For many experiments, the signal generated at the electrode is large enough that the Faraday cage is not necessary. When small signals must be measured, the Faraday cage will shield the cell from many electrical interferences. Unconnected wires and water lines for temperature control passing through the wall of the Faraday cage are sources of line frequency interference for small signals. For best results, remove any unconnected wires and properly ground water lines.

USE OF SOLID WORKING ELECTRODES

The CGME can accommodate solid working electrodes. The black lead is disconnected from the contact pin on the mercury reservoir and connected to the solid electrode. The solid electrode can be inserted into the standard addition port or the mercury electrode can be raised and the solid electrode inserted through the mercury electrode port in the cell top.

SHUTDOWN

When through with the CGME for the day, proper shutdown will insure longer operation without maintenance. Remove, rinse and store reference electrode in appropriate solution (e.g., Ag/AgCl in 3 M NaCl). Remove and clean cell vial. Rinse capillary with distilled or deionized water, wipe dry, wrap tip with small piece of Teflon tape.

Section 4. MAINTENANCE

This section describes some general cautions, maintenance points, electronic troubleshooting, and the procedure for obtaining service.

GENERAL MAINTENANCE

This is a very rugged instrument and with proper care should give years of service. Following is a brief list of cautions and general maintenance considerations that will extend the lifetime of the instrument.

Follow customary, good laboratory practices.

Clean all spills, especially salt solutions, from on or near the cabinet immediately.

Avoid placing unit in a corrosive atmosphere.

Avoid dropping, shaking, and other forms of mechanical abuse since this could cause loosening of components or subassemblies.

Clean gas lines, i.e., rinse and wipe dry, after each use.

Do not bend auxiliary electrode (platinum wire) when removing or placing cell vial. Repeated bending will cause the wire to break.

Cleaning the Capillary

After extended use, the capillary may become dirty. This may result in drops falling off, inconsistent drop size, or retraction of mercury up the capillary after the drop is knocked off. Simple cleaning of the capillary may solve the problem.

1. Remove capillary. Note mercury will leak out capillary when unscrewing from reservoir until stainless steel tube is pulled through septa. If the reservoir is not tipped so the valve is exposed to air, the capillary may be removed, cleaned, and reinserted without having to re-evacuate chamber and re-adjust the valve. Alternatively, the electrode can be pivoted 90° for capillary removal so only the mercury in the capillary will leak out.
2. Inspect tip of capillary for cracks and chips around the orifice. If cracks or chips are present, then discard capillary.
3. Connect aspirator to stainless steel tube. Pull 1 N HNO₃ through capillary for 5 minutes.
4. Pull water through capillary for 5 minutes.
5. Pull methanol through capillary for 30 seconds.
6. Pull air through capillary for 1 minute.

7. Dry capillary before installing. The capillary may be placed in oven to dry, however the oven temperature should NOT EXCEED 60 °C. It may be desirable to silanize the capillary before re-installing in the electrode (see next instructions).

Silanizing the Capillary

Proper function of the mercury electrode requires that water does not “creep” in between the mercury column and the glass wall. This will result in retraction (the end of the mercury column is recessed in the capillary) after a drop is knocked off. Silanizing the bore of the capillary so the glass surface is hydrophobic decreases the creep of water.

Silanization is accomplished by treating the glass with a solution of 5% (vol./vol.) of dichlorodimethylsilane in toluene. NOTE: Silanization should be done in a fume hood while wearing protective clothing, gloves, and eye protection.

1. Start with clean dry capillary.
2. Dip capillary tip in silanizing solution. Capillary action will cause solution to wick up capillary. DO NOT let solution reach stainless steel tube. Leave solution in capillary for 15 minutes to let reaction occur.
3. Blow solution out glass tip of capillary. Do not aspirate solution from capillary or it will passivate the stainless steel tube.
4. Repeat the above dip procedure with methanol. Dip, let sit 15 minutes and blow out of capillary.
5. Let the capillary dry.
6. Install capillary.

Electrode Resistance

Over extended period of time the electrode resistance may increase. Repeated tilting of the electrode and changing the capillary will cause the resistance to increase sooner. The resistance is due to oxidized mercury coating the stainless steel contact and possibly the steel tube at the top of the capillary. The resistance can be checked as follows:

1. Place the capillary tip in a small beaker of mercury. The CGME should be in the SMDE mode.
2. Connect an ohm meter between the mercury contact and a wire placed in the beaker of mercury. The resistance should be approximately 7 ohms.
3. If the resistance is too high, remove the beaker of mercury and rotate the electrode so the contact is pointing up.
4. Remove the contact and wipe the contact with a swab and acetone.

5. After drying, re-insert the contact, return the electrode to the vertical position, and replace the capillary in the beaker of mercury
6. Briefly switch to DME mode to allow the mercury to flow to remove any bubbles in the capillary.
7. Remeasure the resistance.
8. If the resistance is still high, then switch to DME mode and check the resistance.
9. If the resistance drops only a couple tenths of an ohm, the contact is still dirty.
10. If the resistance drops to about 7 ohms then the stainless steel tube on the top of the capillary is passivated.
11. Remove and clean the capillary following the steps for Cleaning the Capillary (page 21).

Replacment of the Valve Seal

The valve seal may become damaged or worn with time. Replacement is relatively easy. Unscrew valve adjustment knob until it raises no further. Pull out assembly, wipe off any mercury residue or droplets. Pull out rubber seal. Press in new seal. Insert assembly into top of electrode. Screw in assembly two turns. Tilt electrode so gap between steel tube and seal is visible. Turn in till gap is barely visible. Return electrode to verticle position. If mercury flow has not started, then pressurize chamber with pipet bulb. Screw in assembly till mercury flow stops. Adjust valve gap and evacuate air bubbles as described in startup procedure.

TROUBLESHOOTING

<u>Symptom</u>	<u>Cause</u>	<u>Solution</u>
Drop falls off	Not enough surface tension (solution and potential dependent)	Use smaller drop
	Cracked capillary tip	replace capillary
	Dirty capillary	clean capillary
	Capillary needs to be silanized	resilanize capillary
	Dirty mercury	replace mercury
<u>Symptom</u>	<u>Cause</u>	<u>Solution</u>

Irreproducible drop size	dirty capillary	clean capillary
	cracked capillary tip	replace capillary
	drop knocker strength not correct	adjust knock strength
	mercury leak through valve seal	adjust valve seal
Mercury leaking from capillary	valve seal not properly adjusted	adjust valve seal (see above)
	damaged valve seal	replace valve seal (see above)
noisy signal	reference tip not in contact with solution	lower reference
	clogged reference frit	replace reference
	air bubble in reference tip	"flick" reference until bubbles are at top
	vibrations	place on pad to dampen vibration
	electrical line frequency interference	use Faraday cage
	spikes in power line	power from a different circuit
variation in peak height	irreproducible drop size	see above
	temperature variation	use water-jacketed cell
	irreproducible stirring with stripping techniques	watch stirring for consistency center cell over motor may need to adjust speed may need different type of stir bar
high resistance (see above discussion)	air bubble in capillary	dispense mercury until air bubble flushed from capillary
	passivation of mercury contact by mercury oxide	clean contact

SERVICE PROCEDURE

There are no user serviceable electronic parts in this unit and all service requests should be referred to BAS service personnel. In certain cases, BAS will provide electronic schematics and service procedures to qualified electronic maintenance facilities but only upon written request and then only on the approval of the Service Coordinator.

If a problem arises and appears equipment oriented, call BAS at (317) 463-4527 and ask for Customer Service (see Section 2).