

## New Orders

We welcome orders for custom brain probes and intracerebral guide cannulae. In order to save time and avoid confusion, we have created this form to assist you in correctly specifying the dimensions of these custom products. You may order probes and/or guides, using this form. The dimensions you specify here will be used by BAS to manufacture your custom parts. Please attach your purchase order - we will refer to it for the number of packages ordered (probes and guides are sold in packages of six). *Please note: There is a 100% cancellation penalty for custom probes and guides - they are not refundable and you can not cancel your order once it is placed. Your signature on this form signifies your acceptance of these specifications and terms.*

## Repeat Orders

If you are reordering custom items from BAS, please enter the lot number from the previous package of custom probes or guides in the space on the order form on page 2. We will compare the dimensions of your previous custom order with the information you have entered below and will notify you if there are any discrepancies.

## Standard BAS Probes and Guides

The dimensions of the membrane and shaft length in the standard BAS brain probes and guides is illustrated. The design of the probe-guide couple allows only the membrane to extend beyond the end of the guide shaft when the probe is inserted. You will note from the diagram that the shaft on the probe is longer than the shaft on the guide. This is because 5 mm of the probe shaft is contained within the body of the guide. Therefore, in any custom configuration involving a probe and a matching guide, you have to add 5 mm for the part of the probe shaft which will be hidden within the guide. Our standard brain probes have a 15 mm shaft length and they fit into our standard guide which has a 10 mm shaft length. The accompanying stylet for the standard guide cannula is also 15 mm long, and does not protrude beyond the end of the guide shaft.

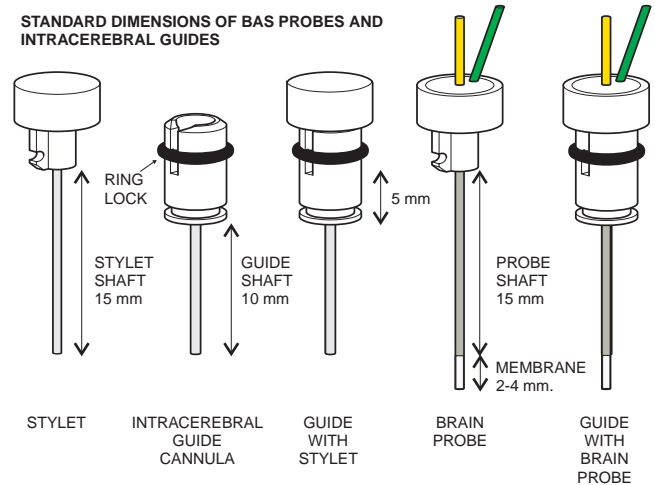

## What to Specify

1. Start with the length of the guide cannula. The standard shaft length on a BAS guide cannula is 10 mm. Enter the desired length of the guide cannula in the order form below, or check the box for standard length. The minimum length is 1 mm. If you don't need a guide cannula, skip to step 2.
2. Next, enter the length of the shaft on the brain probe. This is calculated as the length of the guide shaft, plus 5 mm. The standard length is 15 mm. Enter the desired length of the brain probe shaft in the order form, or check the box for standard length. The minimum length is 6 mm.
3. Finally, specify the length of dialysis membrane needed for the probe. Our standard membrane lengths are 2 and 4 mm. You may order other membrane lengths in 1 mm increments (e.g. 1 mm, 5 mm, 10 mm, etc.). The minimum length is 1 mm. We will not produce membrane lengths less than 1 mm.

## Placing the Order

Use the keyboard to enter all requested information on the order form (page 2), print out, sign the form, and FAX t765-497-1102) or mail (BAS Order Dept., 2701 Kent Ave., W. Lafayette, IN 47906). Your custom probe/guide orders can not be processed until we receive a signed copy of our form, and a copy of the purchase order from your company or university, or credit card information.



# Ordering Custom Brain Microdialysis Probes

## Order Form

◆ Have you read the instructions, order policy and other information on pages 1 and 3? If not, please do so.

◆ Is this a reorder of custom probes previously purchased from BAS?

- No
- Yes

◆ If this is a reorder, please provide the lot number of a package of custom probes from your prior purchase:

Lot No.

◆ Is this a reorder of custom guides previously purchased from BAS?

- No
- Yes

◆ If this is a reorder, please provide the lot number of a package of custom guides from your prior purchase:

Lot No.

◆ Guide Cannula Shaft Length:

- Standard
- Custom:  mm

Preferred Style of Ring Lock:

- Rubber O-Ring (O)
- Steel Omega-Ring (Ω)

◆ Probe Shaft Length:

- Standard
- Custom:  mm

Probe Membrane Length:

- 2 mm
- 4 mm
- Custom:  mm

◆ Your Name:

◆ Your Signature:

◆ Your Company/Affiliation:

◆ Mailing Address:

◆ City:  State:  Country:

◆ Email Address:

◆ Phone:  FAX:

◆ Purchasing Method:  Today's Date:

◆ Card No/PO No:  Expires:



# Ordering Custom Brain Microdialysis Probes

## Disclaimer: Custom Microdialysis Probes and Guides

### Tolerance

In a manufacturing sense, this word means an allowance, or leeway, for slight variations from part to part. The amount of tolerance varies, according to the manufacturing technology being used. Technologies such as CNC machining or laser drilling allow for very tight tolerances, where the variation between pieces is often 0.0001" or even smaller. For items assembled by hand, such as microdialysis probes, larger tolerances are expected. Tolerances in standard BAS microdialysis probes are controlled by the use of specialized tools, called "jigs" which facilitate hand assembly, verify lengths and maintain limits throughout the stages of assembly. Our production jigs maintain our prescribed tolerance for standard 2 mm and 4 mm microdialysis probes, and their corresponding intracerebral guide cannulae.

### Custom Tooling

Custom probes with *alternate membrane lengths* function within the framework of our jig assembly method and can be made to the same tolerances as standard BAS 2 mm and 4 mm probes. *Custom probes or guides with alternate shaft lengths can not be used with our jigs* and must therefore be made using individual measurements, without the tolerance-maintaining benefits of a jig. In other words, we can not promise the same level of tolerance in a custom probe that you have come to expect in a standard probe, unless we manufacture a jig for that custom cannula length. If you plan to utilize large quantities of a particular type of custom probe, or guide, *and* expect tolerances comparable to our standard probes, then it will be necessary for us to build a jig and for you to pay a "tooling charge" to compensate us for the cost of designing and building this jig for you.

### Expected Variations

If you are unwilling to pay for a custom jig, then you must be prepared to accommodate the slight variations from probe to probe, or from guide to guide, that are inevitable with a hand-assembled part. When a custom probe and custom guide, both with non-standard cannula lengths, are combined, a variation of as much as  $\pm 0.3$  mm might occur in the length of the probe relative to the length of the guide. Normally, you would expect the probe membrane to be exposed to tissue beginning at the end of the guide cannula and terminating at the tip of the probe. In a custom situation, the probe cannula might either extend past the end of the guide cannula (thus inserting the membrane further into the tissue) or begin inside the guide cannula (thus shortening the amount of membrane exposed to the tissue). Both situations are possible, within the  $\pm 0.3$  mm tolerance which is realistic for wholly hand-assembled probes and guides made without the benefit of a production jig.

### Acceptance

Your signature on the custom probe order form attests to your understanding of these limitations in custom probe production and acceptance of the expected variations. If such limitations are not acceptable to you, please contact us about the cost of production jigs for probes made with your cannula length. The average cost per jig can be anticipated at approximately \$ 1,500 to \$ 2,000.

All orders for custom probes are subject to approval by BAS. Custom manufactured items will be produced to the specified nominal dimensions within the quoted lead time (up to 6 weeks ARO for most custom orders).